

schiller

Alu Cubicle Plan Range of 3 Cubicles

“Right Corner” Configuration.

Note that cubicles are always numbered from left to right.

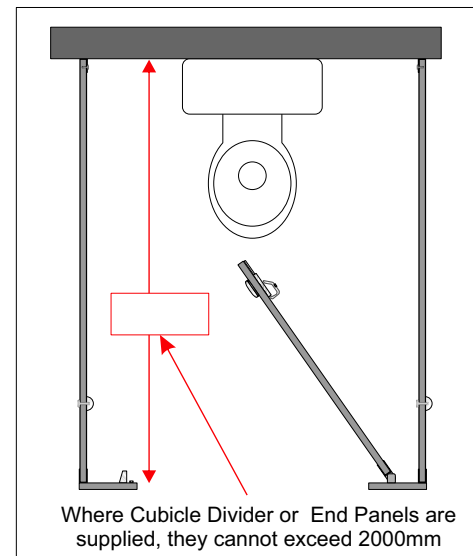
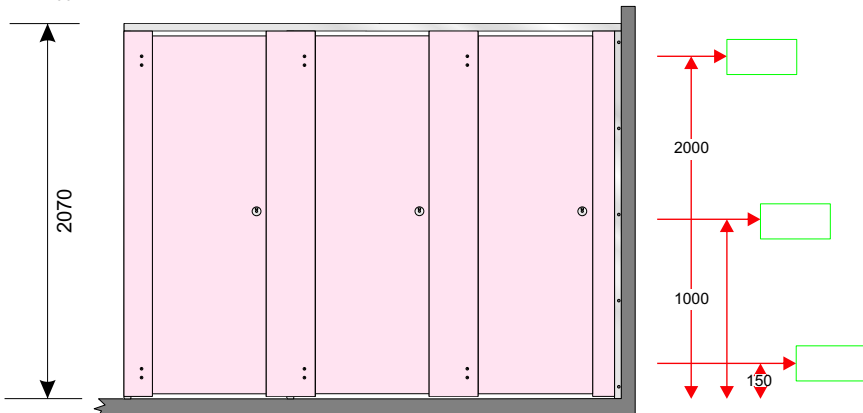
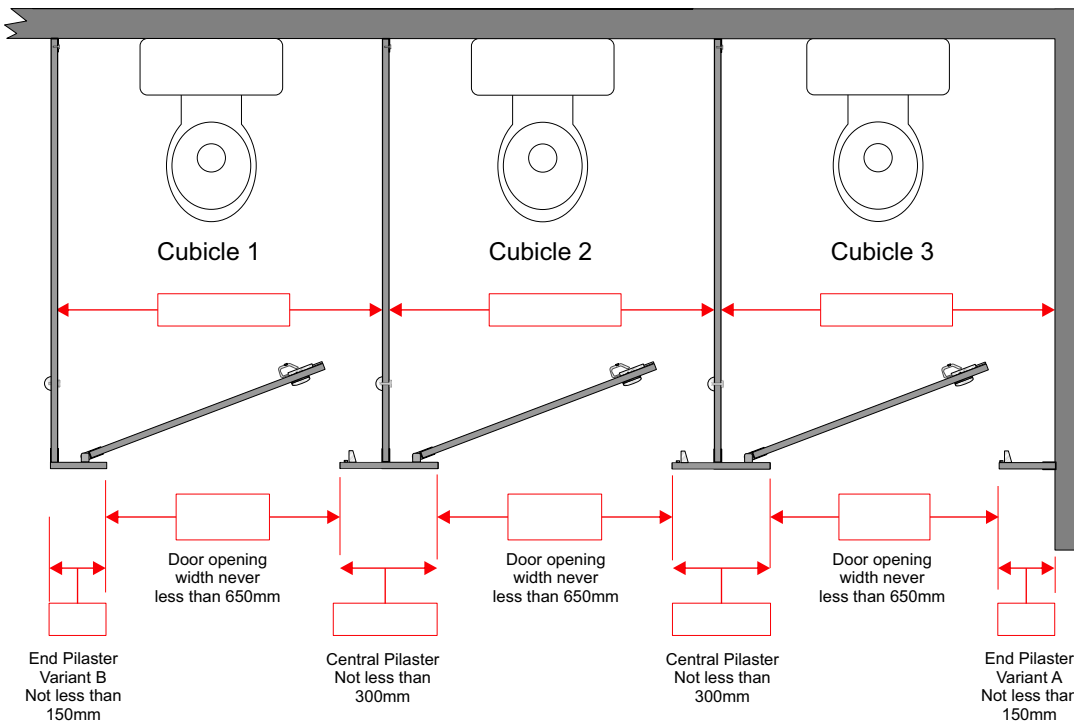

When submitting your order, please fill in this form as completely as possible by inserting the required dimensions in the appropriate boxes. We will use it to fabricate to your requirements and return a copy to you as well as detailed installation instructions when your order is delivered.

Standard cubicles are 2070mm high. If you require a different height please state the dimension in this box. mm

Illustrations show the door hinged on the right. If you require the door to be hinged on the left, please Tick this box.

Please Tick this box if it is required to be wheelchair accessible.

If you require a “cut away” door for children’s use, please Tick this box

To ensure that the supplied kits fit neatly and accurately between the walls and to allow for any vertical deviation between the wall surfaces, please provide the horizontal distance between the walls at the three heights indicated, i.e 150mm, 1000mm and 2000mm from the floor level.

The cubicle dimensions have been calculated based on the information provided to us. No liability can be accepted by Excel Industries for any inaccurate information provided.

Panel Finishes

Door and Filler Panel

Divider Panel

Dimension Plan approved and accepted by

for and on behalf of

Date Form Alu Right Corner 3

Schiller is a division of:

Excel Industries
Coolmine Industrial Estate
Clonsilla Road
Dublin 15

Tel: ++353 (0) 1 8118701
Fax: ++353 (0) 1 8118785
Email: sales@excel-industries.com
Web: www.excel-industries.com

