

When submitting your order, please fill in this form as completely as possible by inserting the required dimensions in the appropriate boxes. We will use it to fabricate to your requirements and return a copy to you as well as detailed installation instructions when your order is delivered.

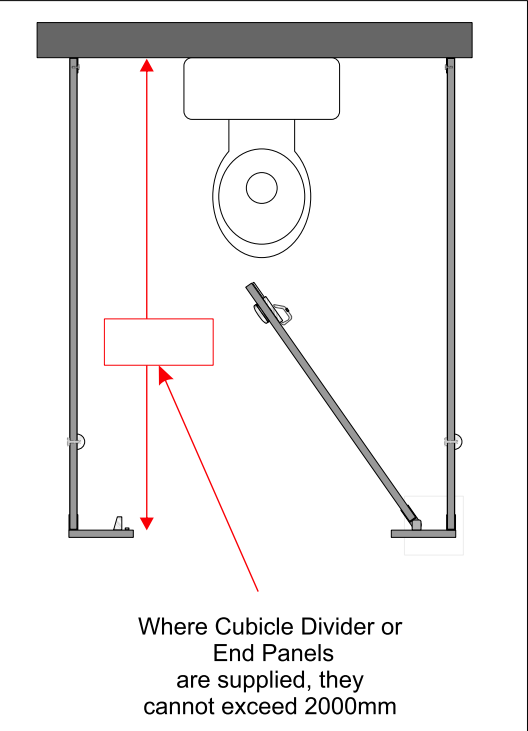

Standard cubicles are 2070mm high. If you require a different height please state the dimension in this box.  mm

Illustrations show the door hinged on the right. If you require the door to be hinged on the left, please Tick this box.

Please Tick this box if it is required to be wheelchair accessible.

If you require a "cut away" door for children's use, please Tick this box

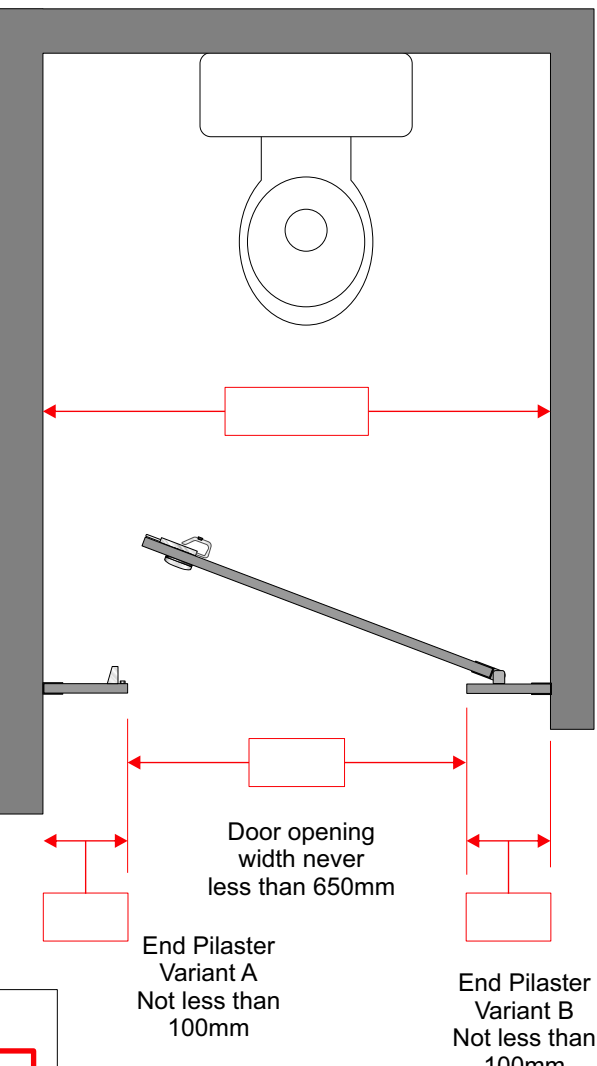

To ensure that the supplied kits fit neatly and accurately between the walls and to allow for any vertical deviation between the wall surfaces, please provide the horizontal distance between the walls at the three heights indicated, i.e 150mm, 1000mm and 2000mm from the floor level.

The cubicle dimensions have been calculated based on the information provided to us. No liability can be accepted by Excel Industries for any inaccurate information provided.

Schiller is a division of:

Excel Industries  
Coolmine Industrial Estate  
Clonsilla Road  
Dublin 15

Tel: ++353 (0) 1 8118701  
Fax: ++353 (0) 1 8118785  
Email: sales@excel-industries.com  
Web: www.excel-industries.com

# schiller Single Cubicle

## Alu Cubicle Plan "Between Walls" Configuration.

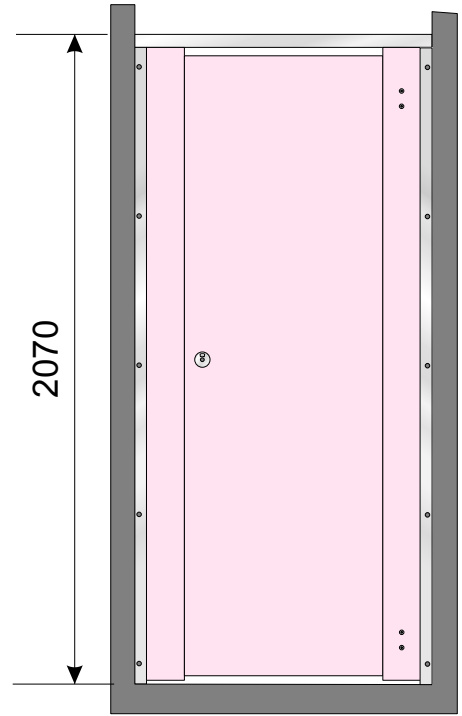

Note that cubicles are always numbered from left to right

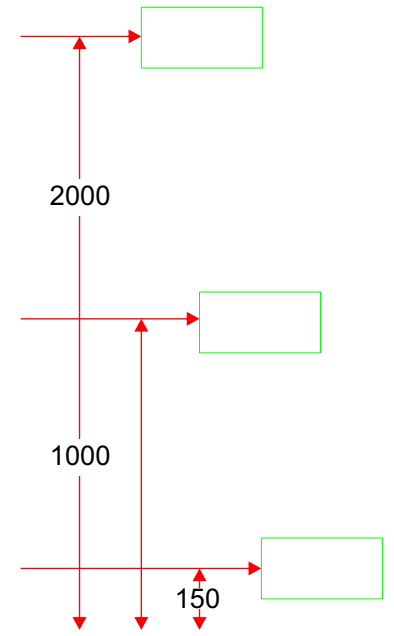

Panel Finishes	
Door and Filler Panel .....	<input type="text"/>
Divider Panel .....	<input type="text"/>

Dimension Plan approved and accepted by

.....  
for and on behalf of

Date .....

Form Alu BW1

